

MMHS (STANAG 4406 Annex E & ACP 142) over STANAG 5066

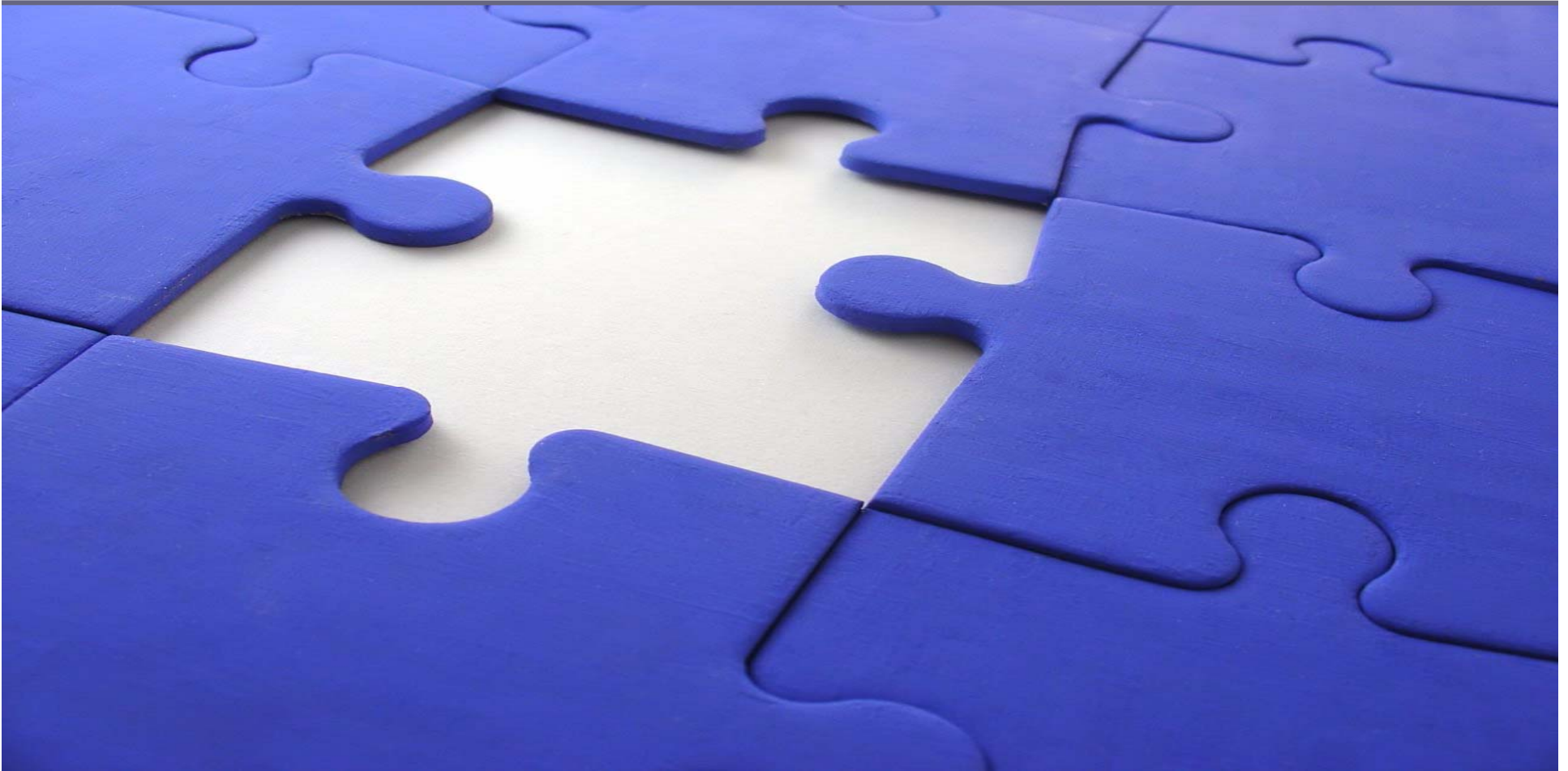

MMHS – Military Message Handling Systems

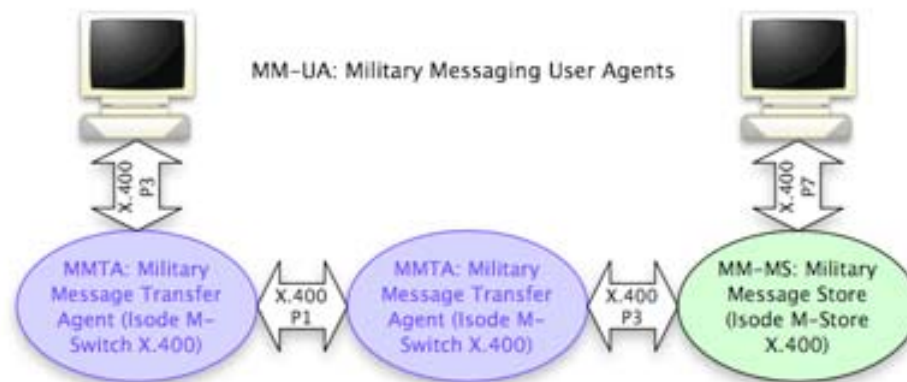

- MMHS: Military Formal Messaging
- Specified in STANAG 4406
 - Replaces older ACP 127 family
- Talk about working over HF Radio



Isode & HF Radio

- Software Product Company
 - Sell to Military, Government, Aviation, Telco
- Server Products
 - X.400 – MMHS/STANAG 4406
 - Internet Messaging
 - IM & Presence (XMPP)
 - Directory – LDAP/X.500/ACP 133
- Plan to have all applications working well over HF Radio



Messaging over Constrained Channels

- Military make use of many constrained communication channels for connectivity
 - HF Radio
 - Satellite
 - VLF Radio (submarines)
 - Speeds down to 10 bits per second
- Technical issues & implications on messaging:
 - Low Bandwidth: messaging needs to optimize bandwidth usage
 - Often broadcast media: messaging should utilize this
- Mobile units may need to operate EMCON
 - Receive data only, in order not to show location
 - Messaging application must support this

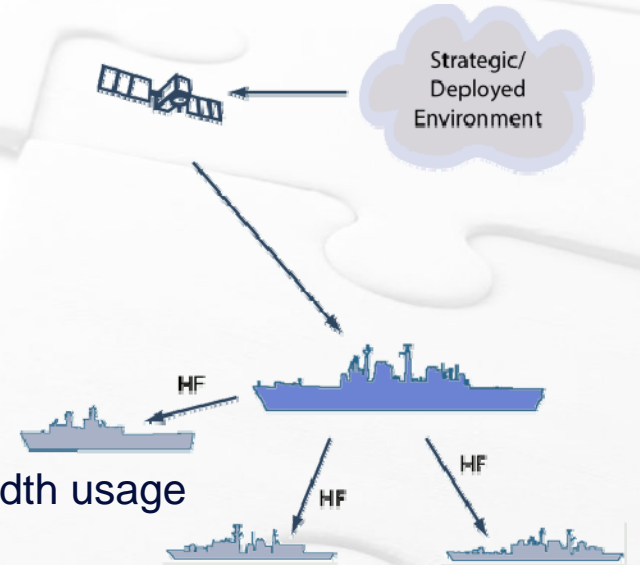

STANAG 4406 Annex E & ACP 142

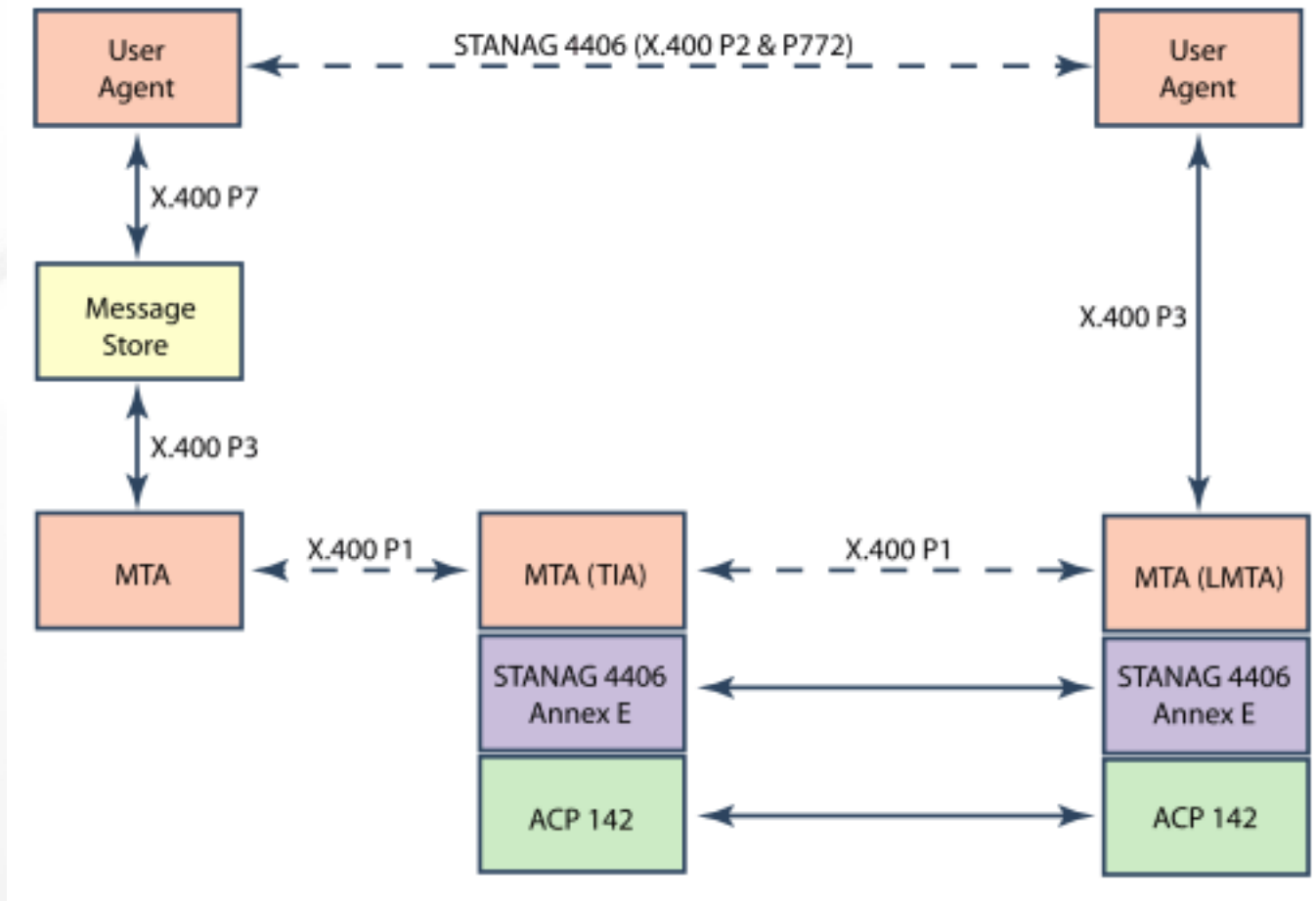

Operation over IP

- Mapping onto UDP/IP good for:
 - VHF and faster radio links
 - Satellite
- Benefits over STANAG 4406 Annex A: (“full stack”)
 - Broadcast
 - Compression
 - Lower latency
 - EMCON

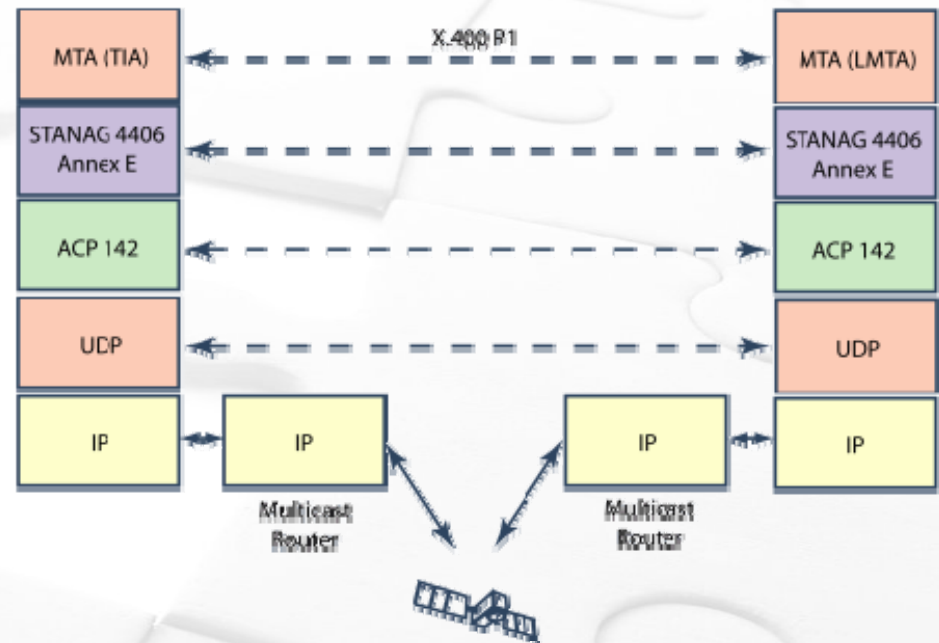

HF Radio

- Important military communications medium
 - Tactical deployment & Satellite backup
 - Point to point and multi-node networks
- Technical difficulties
 - Speed range from very slow to slow (75-9600 baud)
 - Prone to interference and noise
 - Simplex communication (no collision detect)
 - Long turnaround time (seconds to tens of seconds)
 - Causes performance problems for chatty protocols (e.g., anything TCP based)



Why ACP 142 over UDP/IP over HF works badly

- No rate control
 - Rate control is key to fully using link without resending data
- Application retransmission adds significant delay
 - HF Turnaround times force long timers
 - Less of an issue with Satellite and full duplex links
 - So dropping IP packets is bad news
- Setting rate at application works badly, as available rate varies:
 - May be sharing HF with other applications
 - Variable underlying data rate



Operation over HF using STANAG 5066

- STANAG 5066 gives flow control and optimized characteristics for HF
- Also saves IP/UDP protocol overhead
- Isode's M-Switch X.400 implementation believed to be the first

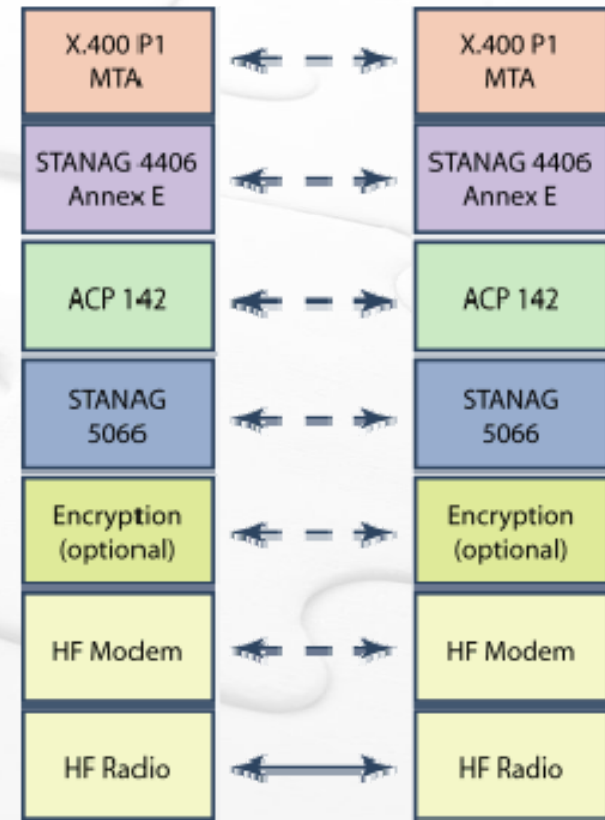

Preliminary Performance Results - Scenario

- Tests performed using three RapidM RM6 Modems
 - Back to back audio link (“perfect” radio)
 - Protocol stack as on previous slide
 - STANAG 4539 waveform
 - 3200 baud
 - Short interleaver
- Measuring ACP 142 + STANAG 5066 performance
 - Data size is ACP 142 input (after STANAG 4406 Annex E Compression)



Preliminary Performance Results

Volume of Data	Number of Messages	Transfer Time	Percentage Line Utilization
1,267 bytes	1	6 sec	44%
3,702 bytes	1	15 sec	51%
7,897 bytes	1	32 sec	62%
24,990 bytes	1	83 sec	75%
30,000 bytes	10	104 sec	73%
73,483 bytes	1	228 sec	81%

- Numbers show good network utilization
- Sharing between messages is efficient



STANAG 4406 Annex E Compression

- Choice of Compression Algorithm
- DEFLATE is the standard and must be supported
- Typically 40% compression for small messages
- Large message compression dependent primarily on the data carried (0-90%).



Feedback on STANAG 5066 (SIS Protocol/Service)

- An excellent approach for the application developer
- Need better flow control – on/off is not enough
 - Control based on priority
 - Control based on destination
- Need standardized management functions
 - Particularly information on speed/quality/status
 - Currently, application developer will need too much S'5066 server specific support
- Need a “last segment bit” in RCOP



Next Steps

- More measurements (and publication)
- Interoperability testing with more S'5066 Servers
 - We are looking for test partners
- Operation over real HF Radio
 - Two Isode partners are planning this



Questions?

- Military Messaging over HF Radio and Satellite using STANAG 4406 Annex (<http://www.isode.com/whitepapers/military-messaging-stanag-4406.html>)
- STANAG 5066: The Standard for Data Applications over HF Radio (<http://www.isode.com/whitepapers/stanag-5066.html>)
- Measuring MMHS Performance over HF Radio and Satellite: STANAG 4406 Annex E Encoding and Compression (<http://www.isode.com/whitepapers/mmhs-hfradio-satellite.html>)
- Military Messaging over HF Radio: A comparison of ACP 127 and STANAG 4406 Annex E (<http://www.isode.com/whitepapers/comparison-acp147-stanag4406.html>)
- Contact: steve.kille@isode.com

