

Analysing the Performance of Dynamic Frequency Selection as a HF Frequency Management Technique

HFIA Meeting 4th February 2010

Connecting & Protecting

© Copyright SELEX Communications. All rights reserved.



- Introduction
- Purpose of the Tests
- DFS Overview
- Test Setup
- Evaluation Method
- Analysis
- Results

- HF2000 HF Radio System has been developed by SELEX Communications Ltd for the Swedish Armed Forces
- It is primarily a 3G Automatic Link Establishment (ALE) System
 - Uses STANAG 4538 to provide link establishment
 - Supports Mil-Std-188-141B ALE
 - Operator manual control
- Design to operate with minimum operator intervention
- The system uses a powerful frequency management tool that uses Dynamic Frequency Selection (DFS) to select frequencies with adequate performance for the traffic type
- Developed by SELEX in partnership with the Swedish Defence Materiel Administration (FMV) and their consultants FOI
- Extensive testing of Dynamic Frequency Selection (DFS) is currently underway

Purpose of the Trial



- To test the Dynamic Frequency Selection algorithm used within the HF2000 HF radio system
 - Requires a methodology to developed to evaluate its performance
- To compare the performance of Dynamic Frequency Selection (DFS) for 3G ALE with that of the 'conventional' fixed frequency pool generation more commonly found with ALE systems
 - To establish the effectiveness of using DFS as a technique for HF2000

What is DFS?



- DFS is a HF frequency management method that allows the automated population of ALE channel frequency pools
- It has a powerful frequency prediction tool embedded that allows it to select frequencies predicted to propagate over the required path
- It overcomes the problem of populating all the nodes in an ALE network by doing this deterministically at each node in the network
- It uses allocated frequency bands rather than actual frequencies
- It uses a pseudo random selection of frequencies to spread the traffic load over the available frequency band

- DFS is more efficient way to manage frequencies
- Provides frequency sharing between networks (synchronous) and within networks
- Provides traffic load management of the HF band
- Increase bandwidth available
- Compatible with existing ALE standards
- Further information on the technique can be found in the IET paper
Advanced HF Spectrum Management Techniques

N.P. Arthur*, I.D. Taylor*, K.D. Eddie*

*SELEX Communications Ltd. UK.

Possible Issues



- Continuously uses different frequencies to perform link establishment
 - Conventional LQA analysis is not available
- Questions we wanted answer to
 - Does the lack of conventional LQA techniques significantly affect the performance of the system?
 - Does the DFS algorithm used in HF2000 produce 'adequate' channels for the traffic to be delivered?

Defining the Performance Parameters



- Establish a number of criteria to compare
 - Directly related to system performance
 - They had to be measurable
 - Avoid complicated data analysis
- The tests developed had to allow direct comparison
 - Within a sensible time frame of measurement.
 - Eliminate as many variables as possible
- Allow comparison between the results and independent frequency prediction programs.
 - Such as REC533 or VOACAP
- Ionosphere soundings taken during the trials

Parameters to be Evaluated



- Links Statistics
 - Link requests made
 - Links successfully made*
 - Link attempt failures
- Frequency Use Analysis
 - Frequencies on which link attempt was successful
 - Frequencies on which link attempt failed
- Link Performance Analysis
 - Message delay (end to end through the system)
 - Message delivered (cumulative)
- AFP Generation performance Analysis
 - Successful links before and after AFP generation against fixed frequency pool

* A successful link is a link that successfully passed the message that it was set up for.

Test Setup

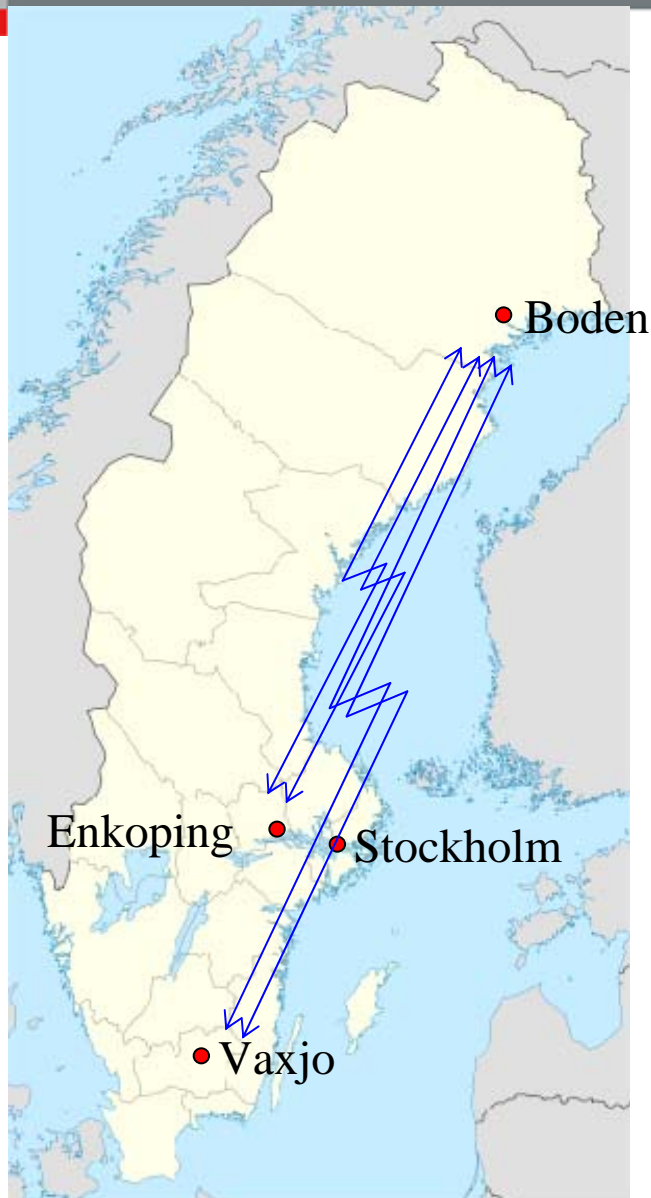

- FMV facilities in Sweden
- Between Boden and Enköping/Vaxjo
- Identical Equipment types used
- Links of approximately 1000 km
- Initial tests conducted between December 08 and February 09
- More tests are planned for late spring 2010

Trials Test Configuration

- Two identical links
- Traffic submitted to each net simultaneously
 - To remove propagation variations
- One net set for fixed frequency pool selection the other set for AFP

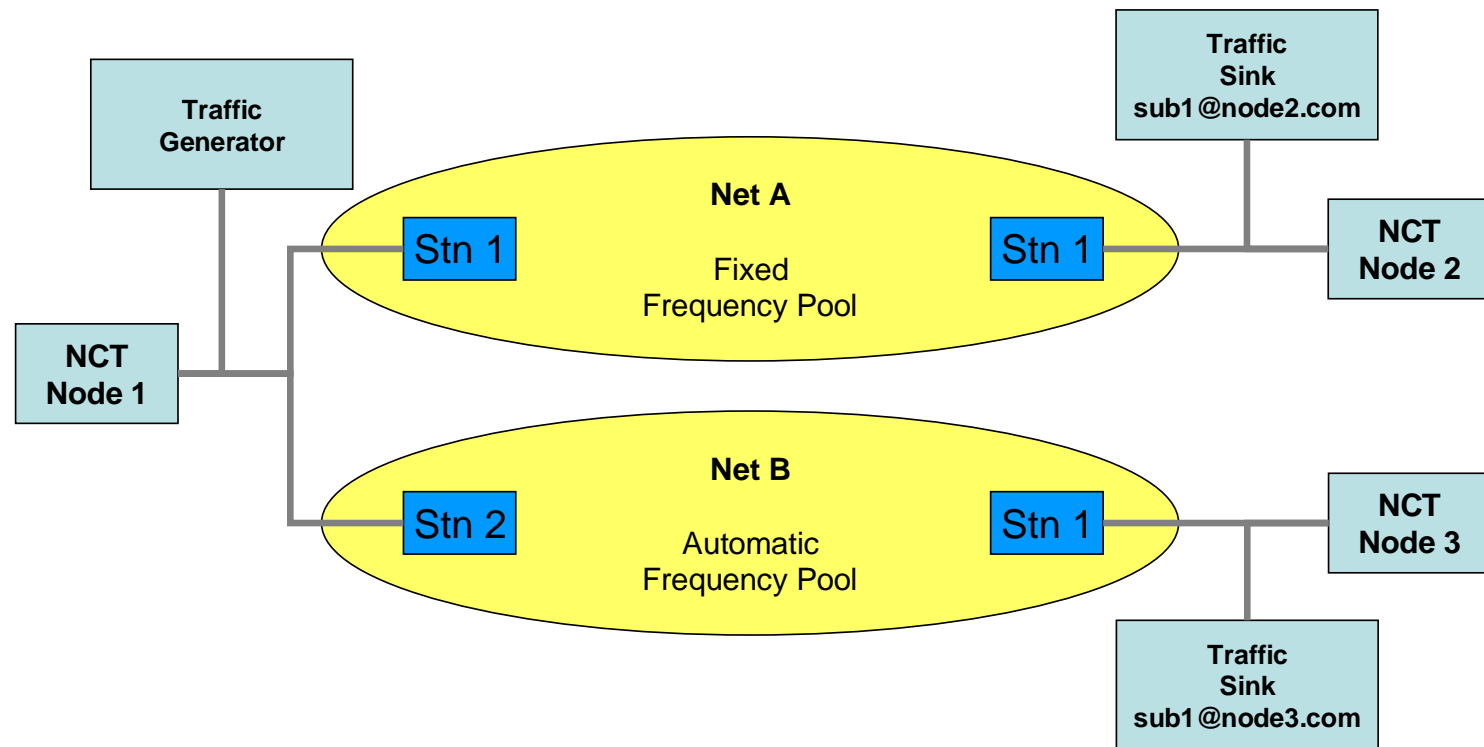

- **Traffic types**

- ARQ with Email
- ARQ with IP datagrams

- **Frequency Management for Net A & B**

- 3G Frequency Information (subset)
- AFP Size: 12
- Threshold SNR: 15dB
- AFP Duration: 30 mins
- Frequency Mode: Single Freq

- **Traffic Transfer**

- Fixed data rate
- Modem Waveform: STANAG 4285
- Data Rate: 1200bps
- Interleave: Short

- **Traffic Submission**

- Fixed size E-Mail messages
- Message Size: 2000 bytes
- Message per Hour: 12
- Message Distribution: Regular

- Changes From Email trial
 - IP On-air Linking Attempts Limit
 - Failed Message Transfer Attempts Limit
- IP Trial System Configuration
 - IP datagram size: 5000 bytes (5112 OTA)
 - On-air link attempts: 1
 - Message rate: 12 per hour
 - Failed message attempts: 1
 - Frequency pool size: 12
 - Look ahead: 7
 - AFP duration: 30 minutes

- HF2000 provides a comprehensive logging system that allowed the capture of the HF system activity
- Each log file covered a 24 hour period
- Software was written to turn this raw data into a format that allowed easy comparison between the two frequency management method
- Microsoft excel was used to generate the charts

- The final results of this work will not be presented here
- Results are due to be published in a paper that is due to be presented at the Nordic HF Conference later this year
- The following results are just for illustration of the method used and should not be used to draw any conclusions!!

- Basic link statistics were produced that showed
 - How many links were attempted
 - What percentage were successful
 - What percentage failed
 - Output are in terms of station 1 & 2 as equipment was rotated to eliminate any potential equipment bias.

- Statistics for linking performance
 - Given as a totals and percentage

Link Statistics for the: 30/01/2009			
Station 1	Totals	%	
Link Requests	962.00		
Links Made	207	21.5	
Attempt Failures	755	78.5	

Station 2	Totals	%	
Link Requests	726		
Links Made	462	63.6	
Attempt Failures	264	36.4	

Frequency Selection

- Plot showing successful attempts for both nets
- Clearly shows a typical useable frequency plot for a 24 hour period

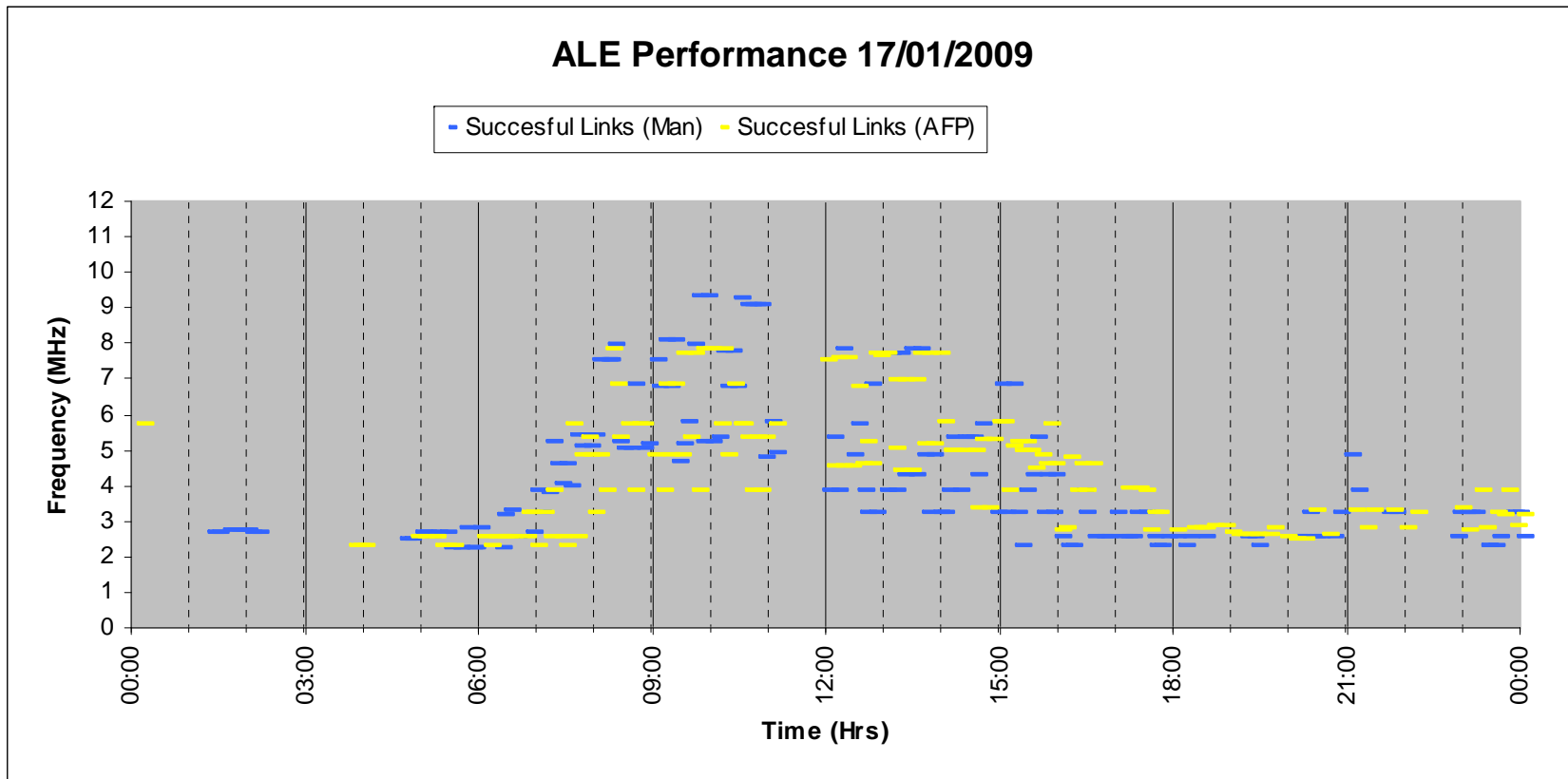

Link Performance



- Graph showing message delay and total number successful links

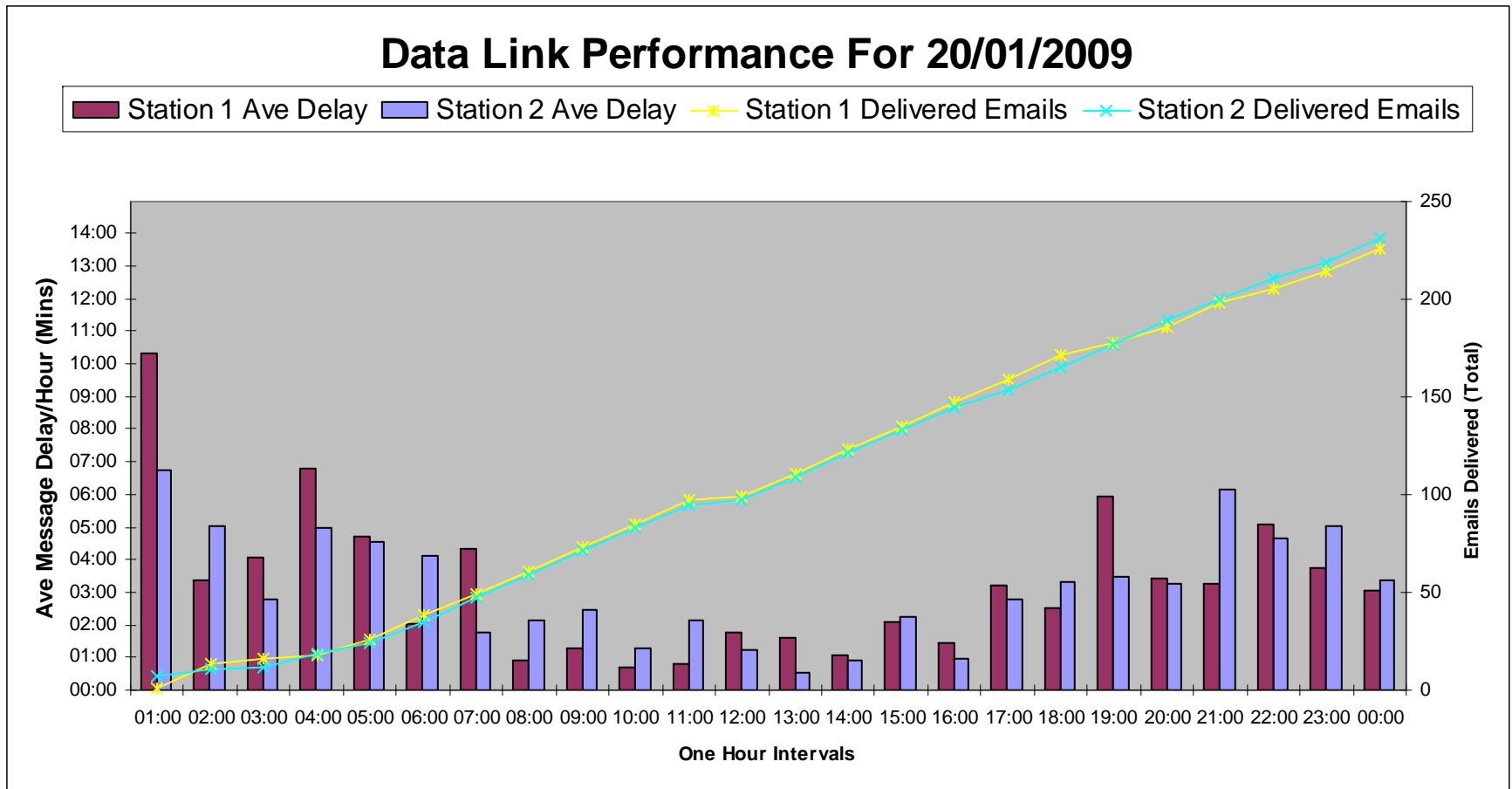

AFP Generation



- Statistics to compare the affect of changing the net frequency pool every 30 minutes
- Compare performance when an AFP is generated
 - 15 minutes before and after a new frequency pool change with that of the net where there is new frequency pool
- Output

Station 1	64 Link Successes for Old AFP	Station 2	84 Link Successes for Old AFP
	63 Link Successes for New AFP		82 Link Successes for New AFP

And Something Interesting!

- A Night time phenomena
 - Observed on several nights

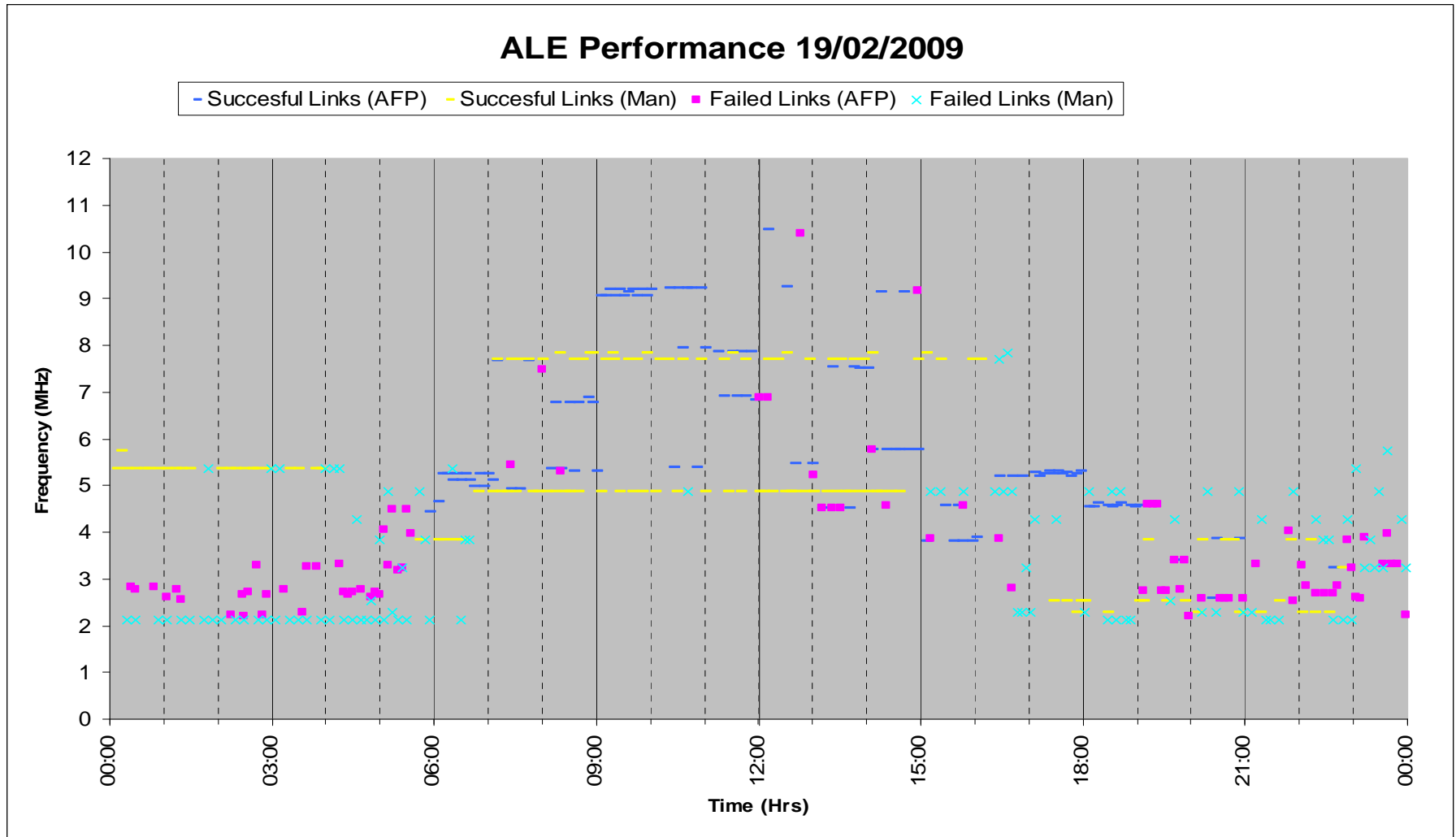

REC533 Predictions February 2009



```

FEB      2009          SSN.=   2.          Path
Boden    VÄXJÖ          AZIMUTHS <Short> N. MI.   KM
65.82 N  21.70 E    56.88 N  14.82 E    203.32  17.27    571.4   1058.1
MIN ANG  3.0 DEG
XMTR  2-30 + 0.0 dBi[samples\SAMPLE.00    ] Az=  0.0 OFFaz=203.3   1.000kW
RCVR  2-30 + 0.0 dBi[samples\SAMPLE.00    ] Az= 17.3 OFFaz=360.0
NOISE -150 dBW          S/N 90% of Days @ 45 dB in 1 Hz RX Bandwidth
    
```

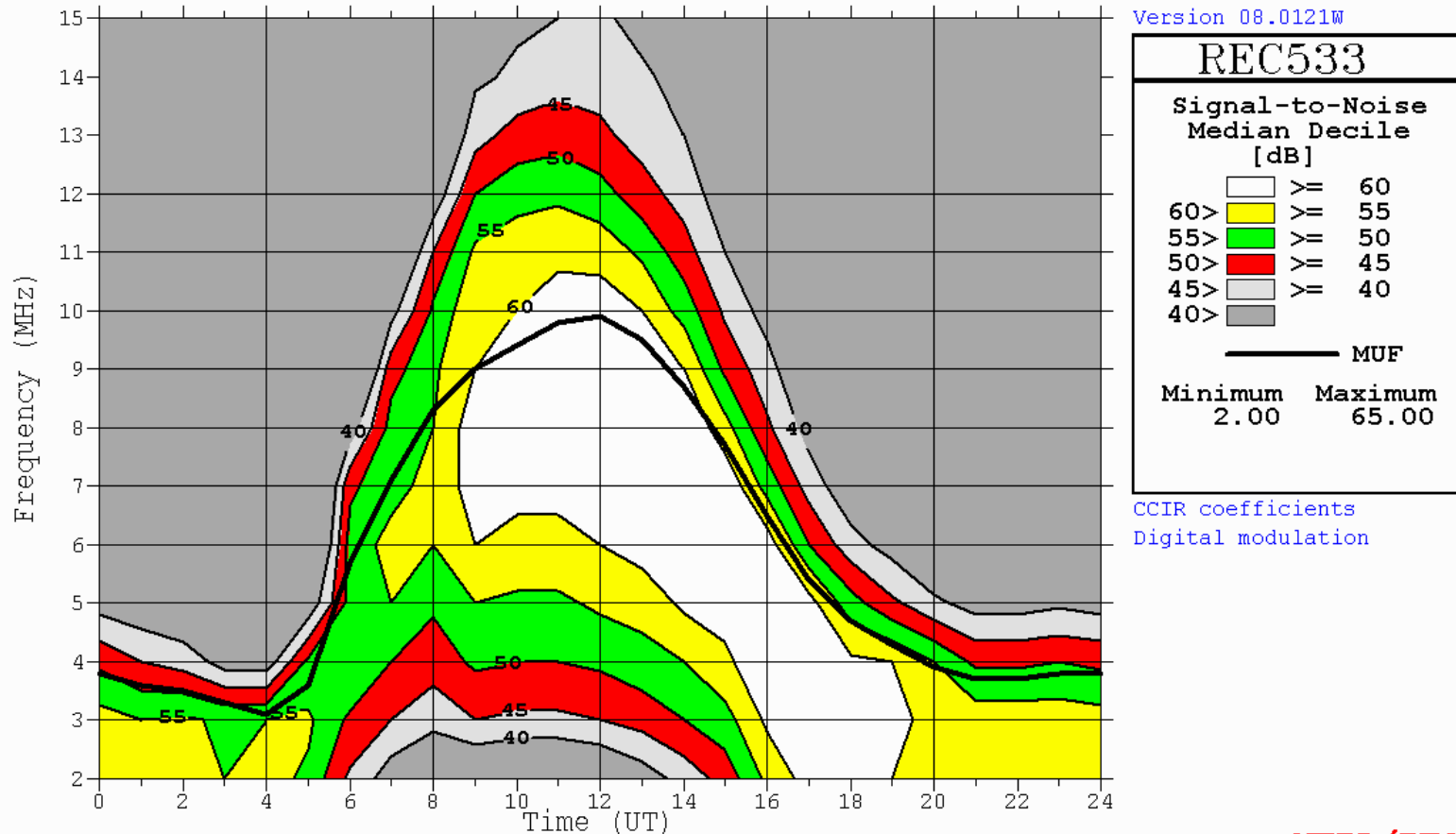

Ionosphere Sounding

- Not predicted by REC533

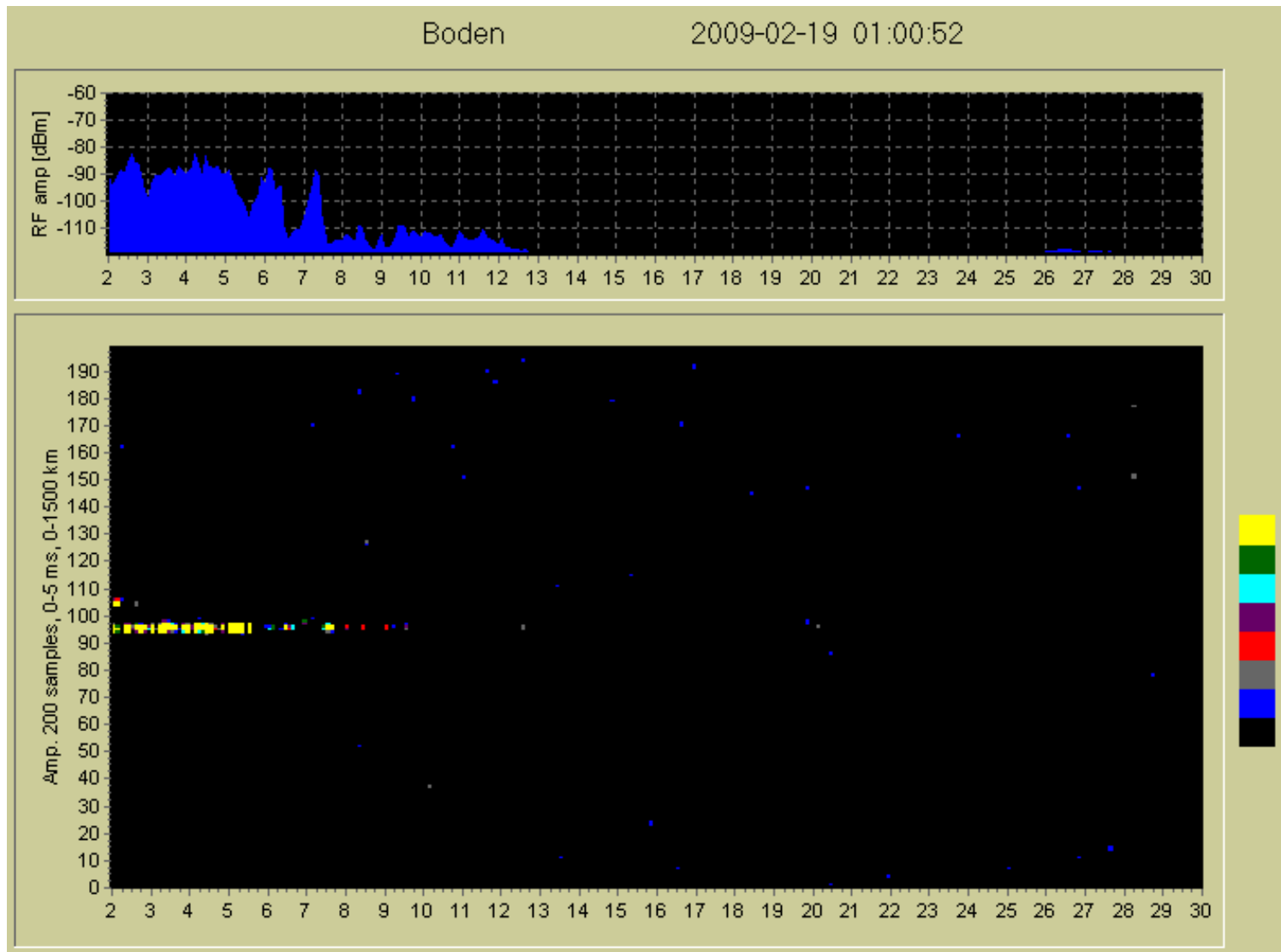

Ionosphere Sounding 2

- Same time the following night

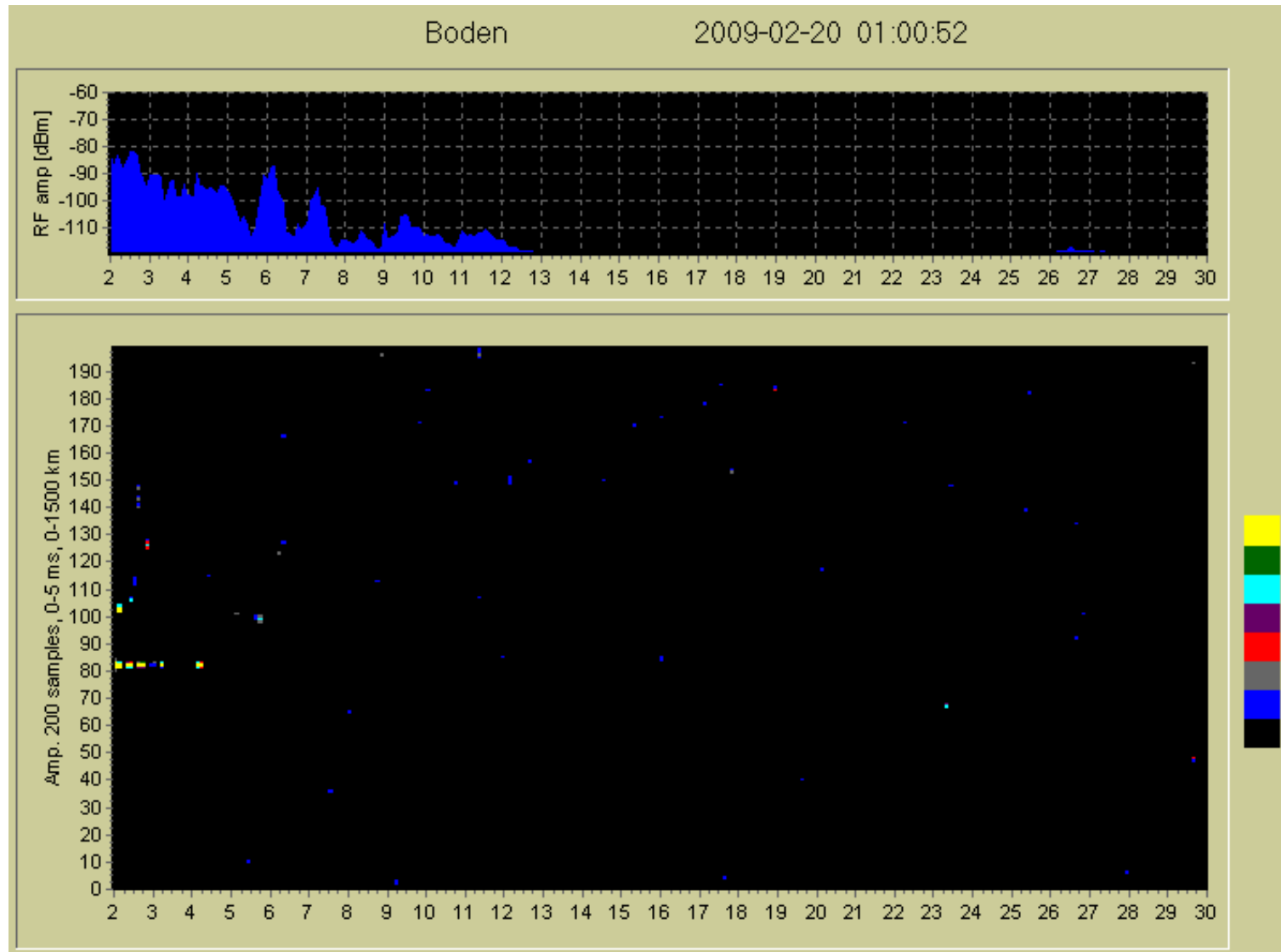

Another example!

- Not predicted by REC533

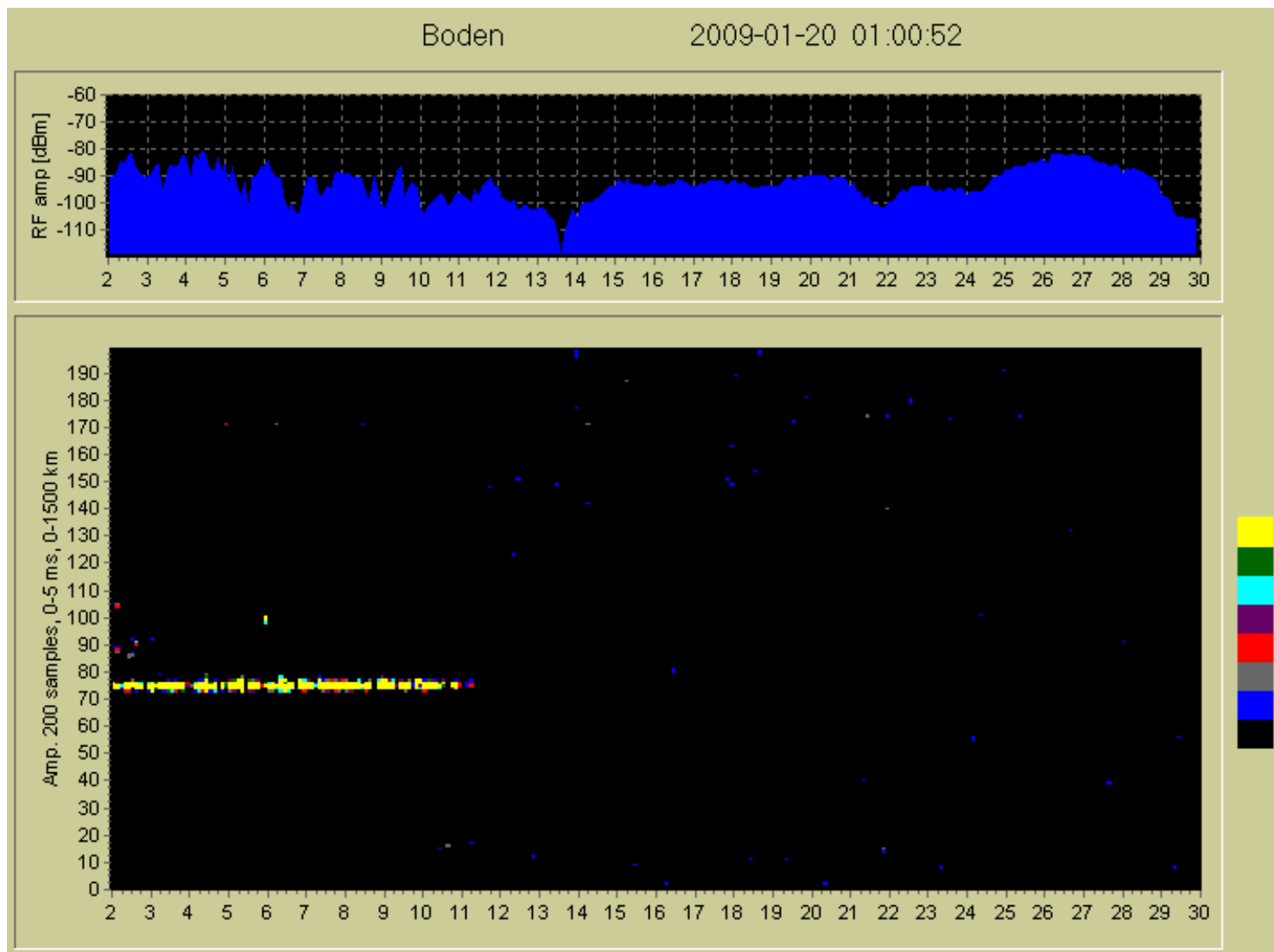

A Limitation



- Sporadic E events that are not predicted show a limitation in the current algorithm
- Need to develop techniques in the future that will automatically make use sporadic E events.

- A test method has been developed that allows direct comparison between the two methods of frequency management
- A set of test parameters were established that allowed the collected data be analysed in a straightforward way
- Tests have not yet been completed and further trials using this test methodology will be performed later this year
- The full results from the trials conducted are planned to be presented at the Nordic HF Conference*.

**Nordic HF Conference 17-19 August 2010. Fårö Kursgård, Fårö*



End

Any Questions?